



Technical description

Furniture

Base	Stainless steel leg base; stainless steel or powder coated skid base
------	--

Seat	Polyurethane foam, webbing tape
------	---------------------------------

Construction	Slab elements
--------------	---------------

Finish	Fabric, leather
--------	-----------------

Modular walls

Base	Plastic gliders or stainless steel or powder coated metal foot (free-standing walls)
------	--

Construction	The wood based board construction, polyurethane foam
--------------	--

Finish	Fabric
--------	--------













Tables

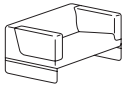

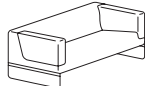
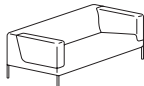

Construction	Skid base made of powder coated or stainless steel
--------------	--

Table tops	MDF finished with natural veneer
------------	----------------------------------

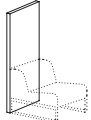
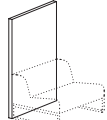
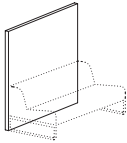
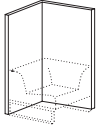
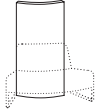
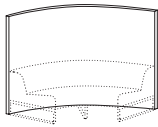

Width × Depth × Height × Seat Height (cm)

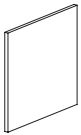
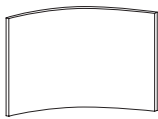
			
TR/P/P 89 x 85 x 40	TR/P/N 89 x 85 x 40	TR/1/P 89 x 85 x 66 x 40	TR/1/N 89 x 85 x 66 x 40
			
TR/2/P 140 x 85 x 66 x 40	TR/2/N 140 x 85 x 66 x 40	TR/3/P 190 x 85 x 66 x 40	TR/3/N 190 x 85 x 66 x 40
			
TM/1 60 x 85 x 66 x 40	TM/2 120 x 85 x 66 x 40	TM/3 180 x 85 x 66 x 40	TM/N 85 x 85 x 66 x 40
			
TM/W 213 x 107 x 66 x 40	TM/Z 213 x 107 x 66 x 40	TM/SS/1 60 x 7 x 150	TM/SS/2 120 x 7 x 150
			
TM/SS/3 180 x 7 x 150	TM/SS/N 92 x 92 x 150	TM/SS/Z 85 x 25 x 150	TM/SS/W 221 x 49 x 150

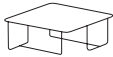
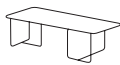
			
TM/SW/S 60 x 7 x 150	TM/SW/M 120 x 7 x 150	TM/SW/L 180 x 7 x 150	TM/SW/W 221 x 49 x 150
			
TR/SO 55 x 39	TR/SMK 75 x 75 x 39	TR/SDK 100 x 100 x 39	TR/SL 120 x 50 x 39